



## STUDY CASE

### **Electric urban Public Transport in Craiova Municipality is covering about 50% of the overall local Public Transport demand.**

RAT Craiova, the URTP demonstrator in RECODRIVE project with European financing, applying some measures to reduce fuel consumption in its bus fleet, is also concerned with energy savings within its Public Transport system by trams.

In the European project MODERN RAT Craiova has the opportunity to install new choppers (electronic equipment known as a power converter or a variable direct voltage regulator), on 9 second-hand trams, in order to reduce their energy consumption by about 35%. The objective of this investment is to have a more and more sustainable electric urban Public Transport services, taking into account the greater capacity of trams and their priority in traffic (own tracks) besides an excellent environmental footprint/impact.

### **Context and objectives**

Motto: "Let's save ourselves by saving energy"

The transport on the main axis of Craiova city, from east to west, is assured by 26 second hand trams.

The concept of the electric supply system and the tracks for these trams (infrastructure) are quite old, belonging to the '85 years. This is the major reason that the electric Public Transport system in Craiova, both trams and infrastructure, needs considerable improvements.

Another very important reason is to reduce the exploitation costs, in parallel with increasing passengers safety and comfort.

The final goal of this measure is to reduce the energy invoice for the whole electric Public Transport system.

### **Implementation**

The evolution of the solutions applied so far in order to reduce energy consumption registered a spectacular trajectory but most steps have brought negative effects that have been accumulated in time and that have become visible for the majority of policy makers, during the last two decades.

Urban Public Transport by trams is more and more encouraged, old already existent systems being often revived. Among the benefits of a tram transport system we are emphasizing a great passenger transport capacity, its priority in traffic by dedicated tracks and environmentally friendly, contributing with zero pollution in urban areas.

In order to observe the same tendency of improving the quality of local Public Transport services assured by different operators from the European Union, RAT Craiova has to take into consideration environmental requirements, the energy consumptions reduction and planning its services according to the real passengers flow. Therefore it was adopted a solution for modernizing the existing trams through major changes in the driving system.

RAT Craiova, the major Public Transport Company in Craiova city, is endowed with old trams which have not been used for some time, because they have an old fashion driving system and a high power input/consumption. This system can be replaced by a system with chopper driving system, 9 trams being able again to be used with a low power consumption.

Due to the chopper's electric circuit, currents of hundred amperes are appearing in trams driving system, for short intervals (few  $\mu$ s). These currents may disturb different electric systems existing in the proximity of the chopper. These disturbances can be avoided by using a radiofrequency filter, in series with the input filter and the smoothing coils from the chopper's power circuit.

Simulations of the filtering circuits shown their influence over the operation of a trams electric energy supplying system.

Using a program dedicated to the electric circuit analysis (like SPICE), the variations of the voltage when the radiofrequency filter is present or absent can be illustrated.

Experimental determinations were performed on a tram, subject to modernization, with respect to the driving system chopper. The voltage at chopper's output and the current absorbed from the electric supplying network were recorded. The recordings were achieved for various current steps of acceleration (corresponding to the acceleration treadle pressing by driver) and respectively for the braking regime on a tram that uses chopper. The different steps for current at acceleration and braking were observed. In the same time the numerical records emphasize the choppers' efficiency, including the processes for the electric energy regeneration (through braking energy regeneration – whenever other consumers are absorbing energy from this tram D.C. supplying system).

The efficiency of the input filter may also be noticed, thanks to the capacitor of this filter discharging, the energy transmitted through resistive couplings toward network and inductive couplings (between the motors of a same chopper) had no influence over the supplying line, the braking regeneration regime being normal.

### Economic aspects

Regarding the chopper, its price for one tram is estimated to 55,500 euro of which:

- a chopper for two electric motors (two electric motors per tram) with energy regeneration function – innovative (about 34,500 euro)
- auxiliary drive source (about 9,800 euro)
- on board computer (about 3,700 euro)
- Mechanical and electrical adjustments to the new system (about 7,500 euro)

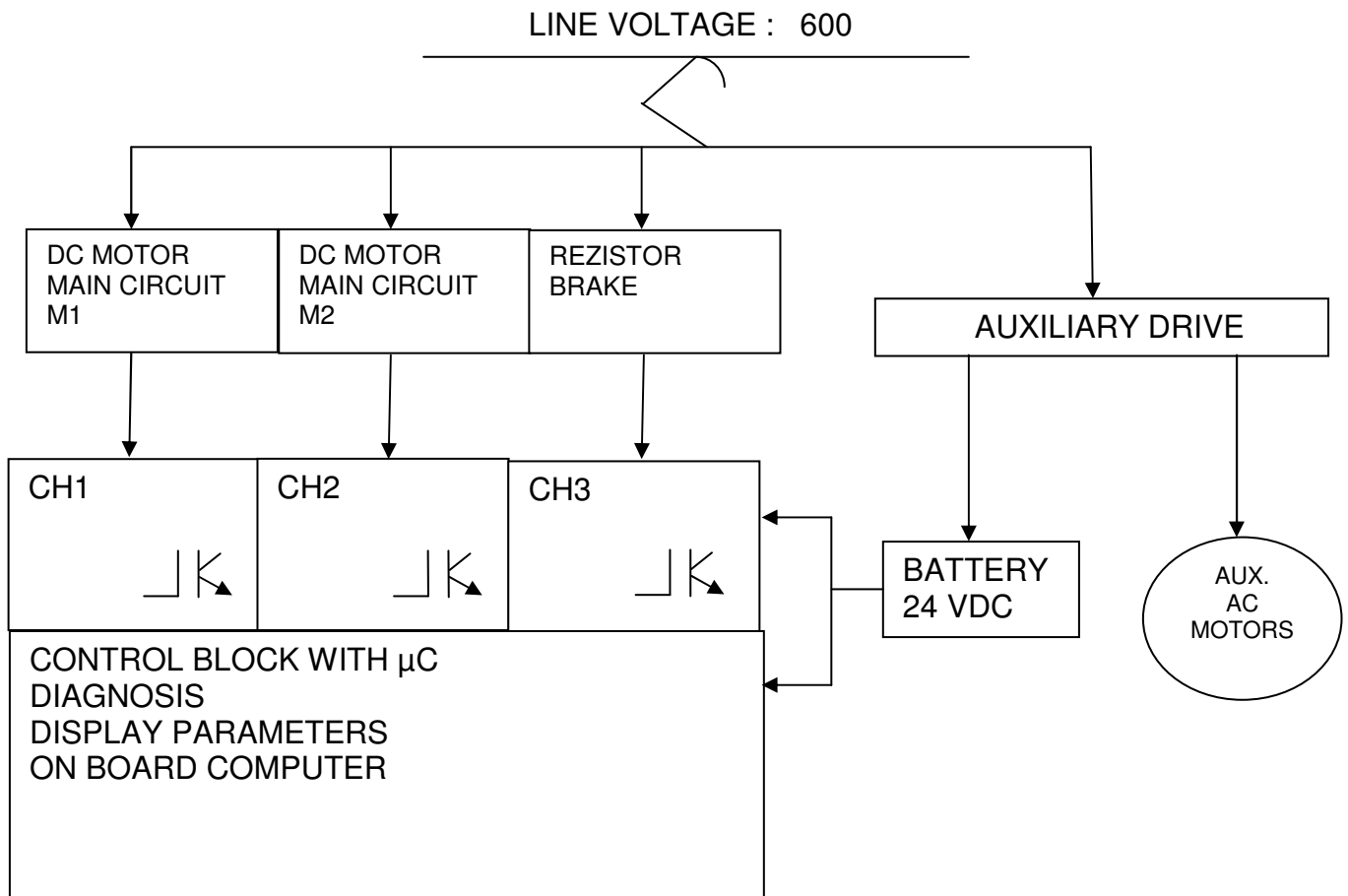

### Legend for the above scheme of a tram with choppers

- Auxiliary drive – DC static converter for supplying battery DC choppers and other electrical consumers
- Auxiliary motor – AC motor for pneumatic brake compressor
- DC motor main circuit 1 – DC supply with line voltage and contactors for forwarded and reversed turns
- DC motor main circuit 2 – DC supply with line voltage and contactors for forwarded and reversed turns
- Brake resistor – DC resistor for dynamic braking (when there are no energy regeneration conditions)
- CH1 – chopper number 1
- CH2 – chopper number 2
- CH3 – DC brake chopper

### Conclusions

Taking into account the project's progress, the results are:

- Improving passengers comfort by eliminating the start-up and braking shocks
- **Reducing power consumption by about 35%**
- activation of the circuit's contactor with 0 power.

Author: URTP Bucuresti and RAT Craiova teams